



Chapter Goals

Describe the history of Frame Relay.

Describe how Frame Relay works.

Describe the primary functionality traits of Frame Relay.

Describe Frame Relay network implementation.

Describe the format of Frame Relay frames.

Frame Relay

Introduction

Frame Relay is a high-performance WAN protocol that operates at the physical and data link layers of the OSI reference model. Frame Relay originally was designed for use across Integrated Services Digital Network (ISDN) interfaces. Today, it is used over a variety of other network interfaces as well. This chapter focuses on Frame Relay's specifications and applications in the context of WAN services.

Frame Relay is an example of a packet-switched technology. Packet-switched networks enable end stations to dynamically share the network medium and the available bandwidth. The following two techniques are used in packet-switching technology:

- Variable-length packets
- Statistical multiplexing

Variable-length packets are used for more efficient and flexible data transfers. These packets are switched between the various segments in the network until the destination is reached.

Statistical multiplexing techniques control network access in a packet-switched network. The advantage of this technique is that it accommodates more flexibility and more efficient use of bandwidth. Most of today's popular LANs, such as Ethernet and Token Ring, are packet-switched networks.

Frame Relay often is described as a streamlined version of X.25, offering fewer of the robust capabilities, such as windowing and retransmission of last data that are offered in X.25. This is because Frame Relay typically operates over WAN facilities that offer more reliable connection services and a higher degree of reliability than the facilities available during the late 1970s and early 1980s that served as the common platforms for X.25 WANs. As mentioned earlier, Frame Relay is strictly a Layer 2 protocol suite, whereas X.25 provides services at Layer 3 (the network layer) as well. This enables Frame Relay to offer higher performance and greater transmission efficiency than X.25, and makes Frame Relay suitable for current WAN applications, such as LAN interconnection.

Frame Relay Standardization

Initial proposals for the standardization of Frame Relay were presented to the Consultative Committee on International Telephone and Telegraph (CCITT) in 1984. Because of lack of interoperability and lack of complete standardization, however, Frame Relay did not experience significant deployment during the late 1980s.

A major development in Frame Relay's history occurred in 1990 when Cisco, Digital Equipment Corporation (DEC), Northern Telecom, and StrataCom formed a consortium to focus on Frame Relay technology development. This consortium developed a specification that conformed to the basic Frame Relay protocol that was being discussed in CCITT, but it extended the protocol with features that provide additional capabilities for complex internetworking environments. These Frame Relay extensions are referred to collectively as the Local Management Interface (LMI).

Since the consortium's specification was developed and published, many vendors have announced their support of this extended Frame Relay definition. ANSI and CCITT have subsequently standardized their own variations of the original LMI specification, and these standardized specifications now are more commonly used than the original version.

Internationally, Frame Relay was standardized by the International Telecommunication Union—Telecommunications Standards Section (ITU-T). In the United States, Frame Relay is an American National Standards Institute (ANSI) standard.

Frame Relay Devices

Devices attached to a Frame Relay WAN fall into the following two general categories:

- Data terminal equipment (DTE)
- Data circuit-terminating equipment (DCE)

DTEs generally are considered to be terminating equipment for a specific network and typically are located on the premises of a customer. In fact, they may be owned by the customer. Examples of DTE devices are terminals, personal computers, routers, and bridges.

DCEs are carrier-owned internetworking devices. The purpose of DCE equipment is to provide clocking and switching services in a network, which are the devices that actually transmit data through the WAN. In most cases, these are packet switches. Figure 10-1 shows the relationship between the two categories of devices.

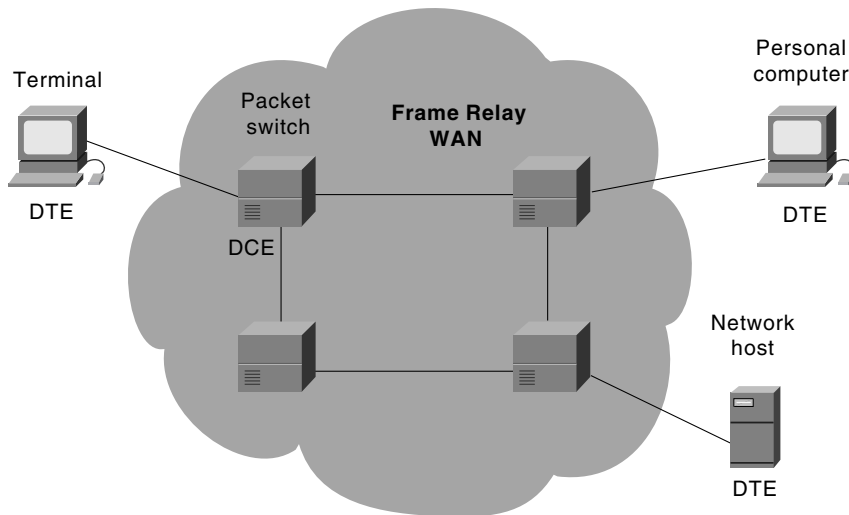
Figure 10-1 *DCEs Generally Reside Within Carrier-Operated WANs*

The connection between a DTE device and a DCE device consists of both a physical layer component and a link layer component. The physical component defines the mechanical, electrical, functional, and procedural specifications for the connection between the devices. One of the most commonly used physical layer interface specifications is the recommended standard (RS)-232 specification. The link layer component defines the protocol that establishes the connection between the DTE device, such as a router, and the DCE device, such as a switch. This chapter examines a commonly utilized protocol specification used in WAN networking: the Frame Relay protocol.

Frame Relay Virtual Circuits

Frame Relay provides connection-oriented data link layer communication. This means that a defined communication exists between each pair of devices and that these connections are associated with a connection identifier. This service is implemented by using a Frame Relay virtual circuit, which is a logical connection created between two data terminal equipment (DTE) devices across a Frame Relay packet-switched network (PSN).

Virtual circuits provide a bidirectional communication path from one DTE device to another and are uniquely identified by a data-link connection identifier (DLCI). A number of virtual circuits can be multiplexed into a single physical circuit for transmission across the network. This capability often can reduce the equipment and network complexity required to connect multiple DTE devices.

A virtual circuit can pass through any number of intermediate DCE devices (switches) located within the Frame Relay PSN.

Frame Relay virtual circuits fall into two categories: switched virtual circuits (SVCs) and permanent virtual circuits (PVCs).

Switched Virtual Circuits

Switched virtual circuits (SVCs) are temporary connections used in situations requiring only sporadic data transfer between DTE devices across the Frame Relay network. A communication session across an SVC consists of the following four operational states:

- **Call setup**—The virtual circuit between two Frame Relay DTE devices is established.
- **Data transfer**—Data is transmitted between the DTE devices over the virtual circuit.
- **Idle**—The connection between DTE devices is still active, but no data is transferred. If an SVC remains in an idle state for a defined period of time, the call can be terminated.
- **Call termination**—The virtual circuit between DTE devices is terminated.

After the virtual circuit is terminated, the DTE devices must establish a new SVC if there is additional data to be exchanged. It is expected that SVCs will be established, maintained, and terminated using the same signaling protocols used in ISDN.

Few manufacturers of Frame Relay DCE equipment support switched virtual circuit connections. Therefore, their actual deployment is minimal in today's Frame Relay networks.

Previously not widely supported by Frame Relay equipment, SVCs are now the norm. Companies have found that SVCs save money in the end because the circuit is not open all the time.

Permanent Virtual Circuits

Permanent virtual circuits (PVCs) are permanently established connections that are used for frequent and consistent data transfers between DTE devices across the Frame Relay network. Communication across a PVC does not require the call setup and termination states that are used with SVCs. PVCs always operate in one of the following two operational states:

- **Data transfer**—Data is transmitted between the DTE devices over the virtual circuit.
- **Idle**—The connection between DTE devices is active, but no data is transferred. Unlike SVCs, PVCs will not be terminated under any circumstances when in an idle state.

DTE devices can begin transferring data whenever they are ready because the circuit is permanently established.

Data-Link Connection Identifier

Frame Relay virtual circuits are identified by *data-link connection identifiers (DLCIs)*. DLCI values typically are assigned by the Frame Relay service provider (for example, the telephone company).

Frame Relay DLCIs have local significance, which means that their values are unique in the LAN, but not necessarily in the Frame Relay WAN.

Figure 10-2 illustrates how two different DTE devices can be assigned the same DLCI value within one Frame Relay WAN.

Figure 10-2 A Single Frame Relay Virtual Circuit Can Be Assigned Different DLCIs on Each End of a VC

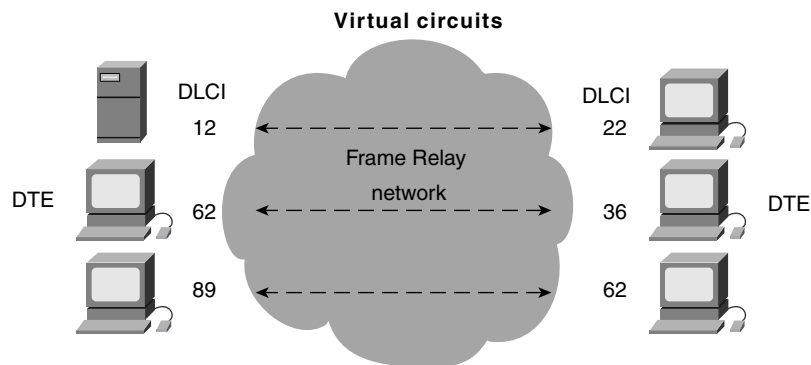

Congestion-Control Mechanisms

Frame Relay reduces network overhead by implementing simple congestion-notification mechanisms rather than explicit, per-virtual-circuit flow control. Frame Relay typically is implemented on reliable network media, so data integrity is not sacrificed because flow control can be left to higher-layer protocols. Frame Relay implements two congestion-notification mechanisms:

- Forward-explicit congestion notification (FECN)
- Backward-explicit congestion notification (BECN)

FECN and BECN each is controlled by a single bit contained in the Frame Relay frame header. The Frame Relay frame header also contains a Discard Eligibility (DE) bit, which is used to identify less important traffic that can be dropped during periods of congestion.

The *FECN bit* is part of the Address field in the Frame Relay frame header. The FECN mechanism is initiated when a DTE device sends Frame Relay frames into the network. If the network is congested, DCE devices (switches) set the value of the frames' FECN bit to 1. When the frames reach the destination DTE device, the Address field (with the FECN bit set) indicates that the frame experienced congestion in the path from source to destination. The DTE device can relay this information to a higher-layer protocol for processing. Depending on the implementation, flow control may be initiated, or the indication may be ignored.

The *BECN bit* is part of the Address field in the Frame Relay frame header. DCE devices set the value of the BECN bit to 1 in frames traveling in the opposite direction of frames with their FECN bit set. This informs the receiving DTE device that a particular path through the network is congested. The DTE device then can relay this information to a higher-layer protocol for processing. Depending on the implementation, flow-control may be initiated, or the indication may be ignored.

Frame Relay Discard Eligibility

The *Discard Eligibility (DE) bit* is used to indicate that a frame has lower importance than other frames. The DE bit is part of the Address field in the Frame Relay frame header.

DTE devices can set the value of the DE bit of a frame to 1 to indicate that the frame has lower importance than other frames. When the network becomes congested, DCE devices will discard frames with the DE bit set before discarding those that do not. This reduces the likelihood of critical data being dropped by Frame Relay DCE devices during periods of congestion.

Frame Relay Error Checking

Frame Relay uses a common error-checking mechanism known as the *cyclic redundancy check (CRC)*. The CRC compares two calculated values to determine whether errors occurred during the transmission from source to destination. Frame Relay reduces network overhead by implementing error checking rather than error correction. Frame Relay typically is implemented on reliable network media, so data integrity is not sacrificed because error correction can be left to higher-layer protocols running on top of Frame Relay.

Frame Relay Local Management Interface

The *Local Management Interface (LMI)* is a set of enhancements to the basic Frame Relay specification. The LMI was developed in 1990 by Cisco Systems, StrataCom, Northern Telecom, and Digital Equipment Corporation. It offers a number of features (called

extensions) for managing complex internetworks. Key Frame Relay LMI extensions include global addressing, virtual circuit status messages, and multicasting.

The LMI global addressing extension gives Frame Relay data-link connection identifier (DLCI) values global rather than local significance. DLCI values become DTE addresses that are unique in the Frame Relay WAN. The global addressing extension adds functionality and manageability to Frame Relay internetworks. Individual network interfaces and the end nodes attached to them, for example, can be identified by using standard address-resolution and discovery techniques. In addition, the entire Frame Relay network appears to be a typical LAN to routers on its periphery.

LMI virtual circuit status messages provide communication and synchronization between Frame Relay DTE and DCE devices. These messages are used to periodically report on the status of PVCs, which prevents data from being sent into black holes (that is, over PVCs that no longer exist).

The LMI multicasting extension allows multicast groups to be assigned. Multicasting saves bandwidth by allowing routing updates and address-resolution messages to be sent only to specific groups of routers. The extension also transmits reports on the status of multicast groups in update messages.

Frame Relay Network Implementation

A common private Frame Relay network implementation is to equip a T1 multiplexer with both Frame Relay and non-Frame Relay interfaces. Frame Relay traffic is forwarded out the Frame Relay interface and onto the data network. Non-Frame Relay traffic is forwarded to the appropriate application or service, such as a private branch exchange (PBX) for telephone service or to a video-teleconferencing application.

A typical Frame Relay network consists of a number of DTE devices, such as routers, connected to remote ports on multiplexer equipment via traditional point-to-point services such as T1, fractional T1, or 56-Kb circuits. An example of a simple Frame Relay network is shown in Figure 10-3.

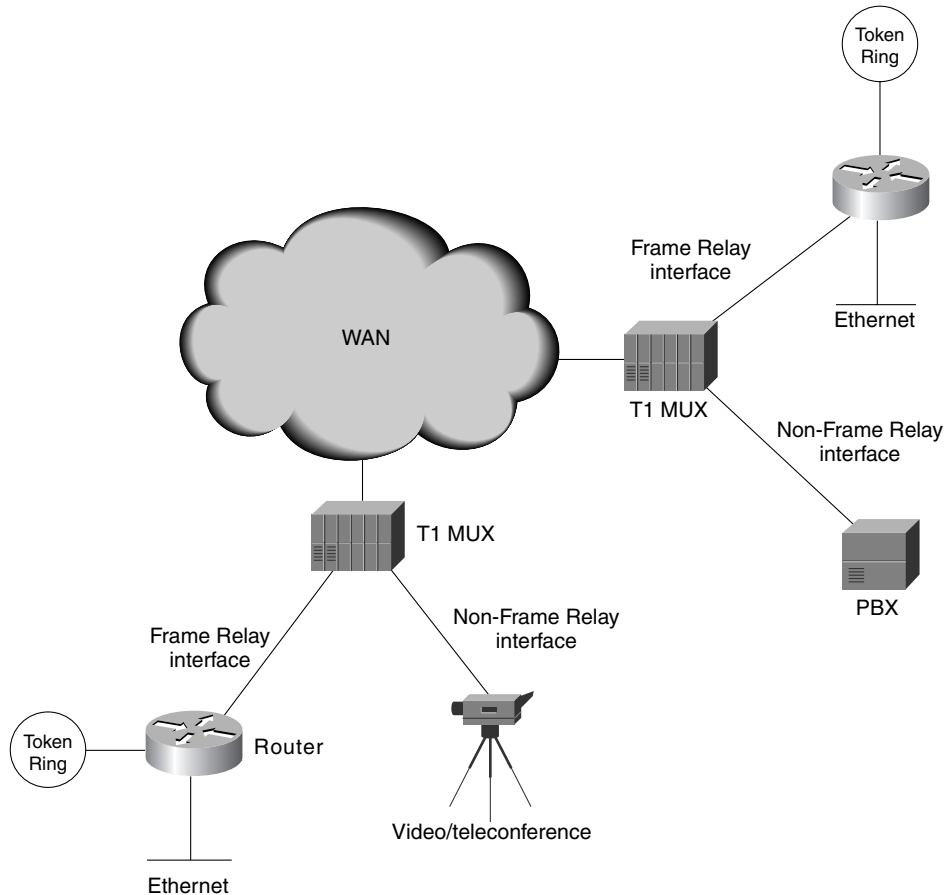
Figure 10-3 *A Simple Frame Relay Network Connects Various Devices to Different Services over a WAN*

The majority of Frame Relay networks deployed today are provisioned by service providers that intend to offer transmission services to customers. This is often referred to as a public Frame Relay service. Frame Relay is implemented in both public carrier-provided networks and in private enterprise networks. The following section examines the two methodologies for deploying Frame Relay.

Public Carrier-Provided Networks

In public carrier-provided Frame Relay networks, the Frame Relay switching equipment is located in the central offices of a telecommunications carrier. Subscribers are charged based on their network use but are relieved from administering and maintaining the Frame Relay network equipment and service.

Generally, the DCE equipment also is owned by the telecommunications provider. DCE equipment either will be customer-owned or perhaps will be owned by the telecommunications provider as a service to the customer.

The majority of today's Frame Relay networks are public carrier-provided networks.

Private Enterprise Networks

More frequently, organizations worldwide are deploying private Frame Relay networks. In private Frame Relay networks, the administration and maintenance of the network are the responsibilities of the enterprise (a private company). All the equipment, including the switching equipment, is owned by the customer.

Frame Relay Frame Formats

To understand much of the functionality of Frame Relay, it is helpful to understand the structure of the Frame Relay frame. Figure 10-4 depicts the basic format of the Frame Relay frame, and Figure 10-5 illustrates the LMI version of the Frame Relay frame.

Flags indicate the beginning and end of the frame. Three primary components make up the Frame Relay frame: the header and address area, the user-data portion, and the frame check sequence (FCS). The address area, which is 2 bytes in length, is comprised of 10 bits representing the actual circuit identifier and 6 bits of fields related to congestion management. This identifier commonly is referred to as the data-link connection identifier (DLCI). Each of these is discussed in the descriptions that follow.

Standard Frame Relay Frame

Standard Frame Relay frames consist of the fields illustrated in Figure 10-4.

Figure 10-4 *Five Fields Comprise the Frame Relay Frame*

Field length,
in bytes

8	16	Variable	16	8
Flags	Address	Data	FCS	Flags

The following descriptions summarize the basic Frame Relay frame fields illustrated in Figure 10-4.

- **Flags**—Delimits the beginning and end of the frame. The value of this field is always the same and is represented either as the hexadecimal number 7E or as the binary number 01111110.
- **Address**—Contains the following information:
 - **DLCI**—The 10-bit DLCI is the essence of the Frame Relay header. This value represents the virtual connection between the DTE device and the switch. Each virtual connection that is multiplexed onto the physical channel will be represented by a unique DLCI. The DLCI values have local significance only, which means that they are unique only to the physical channel on which they reside. Therefore, devices at opposite ends of a connection can use different DLCI values to refer to the same virtual connection.
 - **Extended Address (EA)**—The EA is used to indicate whether the byte in which the EA value is 1 is the last addressing field. If the value is 1, then the current byte is determined to be the last DLCI octet. Although current Frame Relay implementations all use a two-octet DLCI, this capability does allow longer DLCIs to be used in the future. The eighth bit of each byte of the Address field is used to indicate the EA.
 - **C/R**—The C/R is the bit that follows the most significant DLCI byte in the Address field. The C/R bit is not currently defined.
 - **Congestion Control**—This consists of the 3 bits that control the Frame Relay congestion-notification mechanisms. These are the FECN, BECN, and DE bits, which are the last 3 bits in the Address field.

Forward-explicit congestion notification (FECN) is a single-bit field that can be set to a value of 1 by a switch to indicate to an end DTE device, such as a router, that congestion was experienced in the direction of the frame transmission from source to destination. The primary benefit of the use of the FECN and BECN fields is the capability of higher-layer protocols to react intelligently to these congestion indicators. Today, DECnet and OSI are the only higher-layer protocols that implement these capabilities.

Backward-explicit congestion notification (BECN) is a single-bit field that, when set to a value of 1 by a switch, indicates that congestion was experienced in the network in the direction opposite of the frame transmission from source to destination.

Discard eligibility (DE) is set by the DTE device, such as a router, to indicate that the marked frame is of lesser importance relative to other frames being transmitted. Frames that are marked as “discard eligible” should be discarded before other frames in a congested network. This allows for a basic prioritization mechanism in Frame Relay networks.

- **Data**—Contains encapsulated upper-layer data. Each frame in this variable-length field includes a user data or payload field that will vary in length up to 16,000 octets. This field serves to transport the higher-layer protocol packet (PDU) through a Frame Relay network.
- **Frame Check Sequence**—Ensures the integrity of transmitted data. This value is computed by the source device and verified by the receiver to ensure integrity of transmission.

LMI Frame Format

Frame Relay frames that conform to the LMI specifications consist of the fields illustrated in Figure 10-5.

Figure 10-5 *Nine Fields Comprise the Frame Relay That Conforms to the LMI Format*

Field length,
in bytes

1	2	1	1	1	1	Variable	2	1
Flag	LMI DLCI	Unnumbered information indicator	Protocol discriminator	Call reference	Message type	Information elements	FCS	Flag

The following descriptions summarize the fields illustrated in Figure 10-5.

- **Flag**—Delimits the beginning and end of the frame.
- **LMI DLCI**—Identifies the frame as an LMI frame instead of a basic Frame Relay frame. The LMI-specific DLCI value defined in the LMI consortium specification is DLCI = 1023.
- **Unnumbered Information Indicator**—Sets the poll/final bit to zero.
- **Protocol Discriminator**—Always contains a value indicating that the frame is an LMI frame.
- **Call Reference**—Always contains zeros. This field currently is not used for any purpose.
- **Message Type**—Labels the frame as one of the following message types:
 - **Status-inquiry message**—Allows a user device to inquire about the status of the network.

- **Status message**—Responds to status-inquiry messages. Status messages include keepalives and PVC status messages.
- **Information Elements**—Contains a variable number of individual information elements (IEs). IEs consist of the following fields:
 - **IE Identifier**—Uniquely identifies the IE.
 - **IE Length**—Indicates the length of the IE.
 - **Data**—Consists of 1 or more bytes containing encapsulated upper-layer data.
- **Frame Check Sequence (FCS)**—Ensures the integrity of transmitted data.

Summary

Frame Relay is a networking protocol that works at the bottom two levels of the OSI reference model: the physical and data link layers. It is an example of packet-switching technology, which enables end stations to dynamically share network resources.

Frame Relay devices fall into the following two general categories:

- Data terminal equipment (DTEs), which include terminals, personal computers, routers, and bridges
- Data circuit-terminating equipment (DCEs), which transmit the data through the network and are often carrier-owned devices (although, increasingly, enterprises are buying their own DCEs and implementing them in their networks)

Frame Relay networks transfer data using one of the following two connection types:

- Switched virtual circuits (SVCs), which are temporary connections that are created for each data transfer and then are terminated when the data transfer is complete (not a widely used connection)
- Permanent virtual circuits (PVCs), which are permanent connections

The DLCI is a value assigned to each virtual circuit and DTE device connection point in the Frame Relay WAN. Two different connections can be assigned the same value within the same Frame Relay WAN—one on each side of the virtual connection.

In 1990, Cisco Systems, StrataCom, Northern Telecom, and Digital Equipment Corporation developed a set of Frame Relay enhancements called the Local Management Interface (LMI). The LMI enhancements offer a number of features (referred to as extensions) for managing complex internetworks, including the following:

- Global addressing
- Virtual circuit status messages
- Multicasting

Review Questions

Q—*What kind of technology is Frame Relay?*

A—Packet-switched technology.

Q—*Name the two kinds of packet-switching techniques discussed in this chapter, and briefly describe each.*

A—1. In variable-length switching, variable-length packets are switched between various network segments to best use network resources until the final destination is reached.
2. Statistical multiplexing techniques essentially use network resources in a more efficient way,

Q—*Describe the difference between SVCs and PVCs.*

A—A SVC, switched virtual circuit, is created for each data transfer and is terminated when the data transfer is complete. PVC, permanent virtual circuit, is a permanent network connection that does not terminate when the transfer of data is complete. Previously not widely supported by Frame Relay equipment, SVCs are now used in many of today's networks.

Q—*What is the data-link connection identifier (DLCI)?*

A—The DLCI is a value assigned to each virtual circuit and DTE device connection point in the Frame Relay WAN. Two different connections can be assigned the same value within the same Frame Relay WAN—one on each side of the virtual connection.

Q—*Describe how LMI Frame Relay differs from basic Frame Relay.*

A—LMI Frame Relay adds a set of enhancements, referred to as extensions, to basic Frame Relay. Key LMI extensions provide the following functionality: global addressing, virtual circuit status messages, and multicasting.